

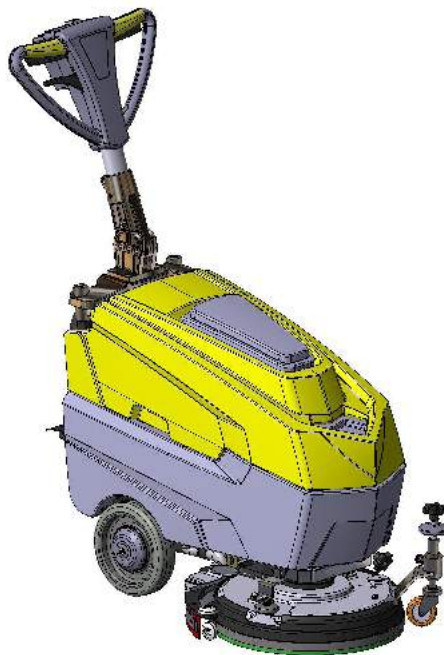

CATALOGO RICAMBI
SPARE PARTS CATALOGUE
MANUEL DES PIECES



F R E C C I A 1 5

MODELLI

M 38 (24V-230V) - Da matr. 050.0214.0343

M 38 (24V-115V)

M 38 Long Run - Da matr. 052.0514.0238

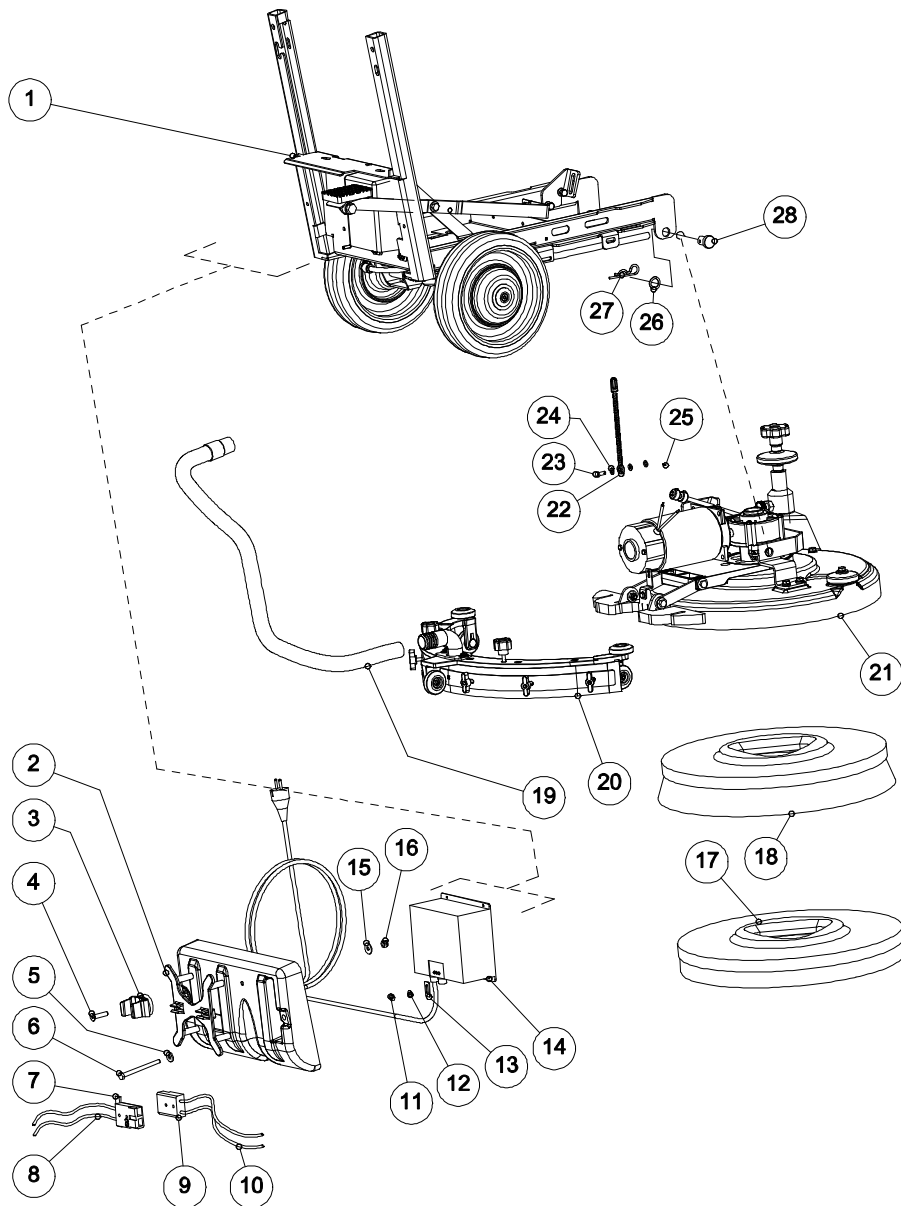

POS.	DESCRIZIONE	DESCRIPTION	DESCRIPTION	Q. tà	COD.	NOTE
1	Gruppo telaio	Chassis group	Frame assembly	1	22.0333.00	
2	Carter	Carter	Carter	1	96.0019.00	●
3	Carter	Carter	Carter	1	96.0037.00	Only for long run ●
4	Fascetta	Collier de serrage	Clamp	1	30.0099.00	
5	Vite	Vis	Screw	1	23.0067.00	
6	Rondella	Rondelle	Washer	2	23.0017.00	
7	Vite	Vis	Screw	2	23.0114.00	
8	Maniglia spina	Plug poignee	Power cable	1	34.0012.00	Only for long run
9	Cavo potenza	Cable d'alimentation	Power cable	1	34.0392.00	Only for long run
10	Spina	Plug	Plug	2	34.0011.00	Only for long run
11	Dado	Ecrou	Nut	1	23.0050.00	
12	Rondella	Rondelle	Washer	1	23.0011.00	
13	Piastrina	Plaque	Plate	1	25.0256.00	
14	Caricabatterie	Chargeur	Battery charger	1	18.0032.00	M38 schuko, Std. ●
	Caricabatterie	Chargeur	Battery charger	1	18.0033.00	M38 USA ●
	Caricabatterie	Chargeur	Battery charger	1	18.0036.00	M38 UK, Opt. ●
	Caricabatterie	Chargeur	Battery charger	1	18.0029.00	Only for long run (external) ●
15	Rondella	Rondelle	Washer	1	23.0017.00	
16	Dado	Ecrou	Nut	1	23.0044.00	
17	Trascinatore	Plateau	Pad holder	1	40.1008.00	Opt.
18	Spazzola	Brosse	Brush	1	40.0008.00	PP Ø 0.7, Std.
	Spazzola	Brosse	Brush	1	40.0108.00	PP Ø 0.9, Opt.
	Spazzola	Brosse	Brush	1	40.0408.00	PP Ø 0.5, Opt.
	Spazzola	Brosse	Brush	1	40.0208.00	Tynex Ø 0.9, Opt.
19	Tubo	Tuyau	Hose	1	95.0065.00	●
20	Gruppo tergitoro	Gr. seceuer	Squeegee assembly	1	22.0134.00	
21	Gr. motore spazzola	Gr. moteur brosse	Brush motor assembly	1	22.0334.00	
22	Cavo	Cable	Wire	1	37.0017.00	
23	Perno	Pivot	Pin	1	33.0135.00	
24	Rondella	Rondelle	Washer	3	23.0022.00	
25	Copiglia	Goupille	Split pin	1	27.0089.00	
26	Rondella	Rondelle	Washer	2	23.0157.00	
27	Copiglia	Goupille	Split pin	2	27.0099.00	
28	Perno	Pivot	Pin	2	33.0078.00	

Std. = First equipment Opt. = Optional



Ghibli S.p.a
Via Circonvallazione, 5
27020 Dorno (PV) ITALY

Tel. +39 0382 848811
Fax +39 0382 84668
<http://www.ghibli.it>
e-mail: info@ghibli.it

